

CODE	F gas CIL.	B mm	CH mm	Pressure
S915-10G	1/8	16	14	350
S915-13G	1/4	18	19	350
S915-17G	3/8	28	22	250
S915-21G	1/2	31	27	210
S915-26G	3/4	36	33	210

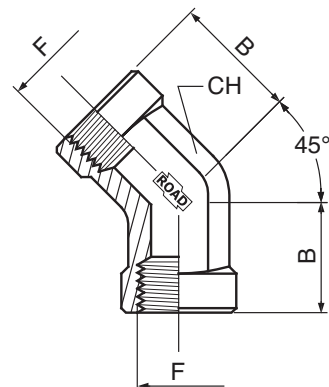

S915

RACCORDO A 45° FEMMINA CON
FILETTATURA BSPP
45° FEMALE UNION WITH BSPP
THREAD



CODE	F gas CIL.	F1 BSPT	B mm	Y mm	CH mm	Pressure
S920-10G	1/8	1/8	17	20	14	350
S920-13G	1/4	1/4	22	28	19	350
S920-17G	3/8	3/8	26	31	22	310
S920-21G	1/2	1/2	31	37	27	210
S920-26G	3/4	3/4	35	40	33	210
S920-33G	1"	1"	44	56	41	140

S920

RACCORDO A 90° DI ESTREMITÀ
FEMMINA/MASCHIO CON
FILETTATURA BSPP/BSPT
90° FEMALE/MALE UNION WITH
BSPT/BSPP THREAD

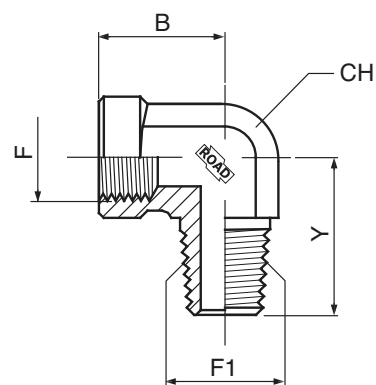

60°

