

D336

**RACCORDO A T CON DADO
GIREVOLE CENTRALE
BRANCH TEE UNION WITH SWIVEL
NUT**

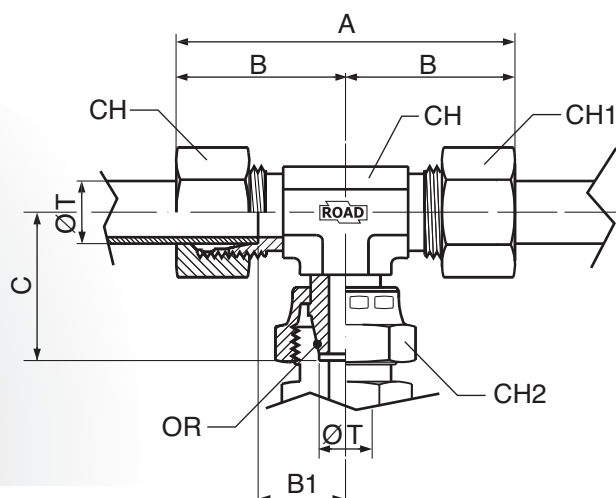

SERIE	T	CODE	CH	CH1	CH2	C	A	B	B1	Pressure
	Ø		mm	mm	mm	mm	mm	mm	mm	Wp
L	6	D336-06-06L	12	14	14	26	53	27	12	315
L	8	D336-08-08L	12	17	17	27,5	56,5	29	14	315
L	10	D336-10-10L	14	19	19	29	59	30	15	315
L	12	D336-12-12L	17	22	22	29,5	61,5	32	17	315
L	15	D336-15-15L	19	27	27	32,5	68,5	36	21	315
L	18	D336-18-18L	24	32	32	35,5	75,5	40	23,5	315
L	22	D336-22-22L	27	36	36	38,5	82,5	44	27,5	160
L	28	D336-28-28L	36	41	41	41,5	88,5	47	30,5	160
L	35	D336-35-35L	41	50	50	51	107	56	34,5	160
L	42	D336-42-42L	50	60	60	56	119	63	40	160
S	6	D336-06-06S	12	17	17	27	58	31	16	630
S	8	D336-08-08S	14	19	19	27,5	59,5	32	17	630
S	10	D336-10-10S	17	22	22	30	64	34	17,5	630
S	12	D336-12-12S	17	24	24	31	69	38	21,5	630
S	14	D336-14-14S	19	27	27	35	75	40	22	630
S	16	D336-16-16S	24	30	30	36,5	79,5	43	24,5	400
S	20	D336-20-20S	27	36	36	44,5	92,5	48	26,5	400
S	25	D336-25-25S	36	46	46	50	104	54	30	400
S	30	D336-30-30S	41	50	50	55	117	62	35,5	400
S	38	D336-38-38S	50	60	60	63	135	72	41	315