

# D382

**RACCORDO A T ORIENTABILE  
LATERALE CON FILETTATURA  
METRICO CILINDRICA ISO 6149-2  
RUN TEE ADJUSTABLE UNION  
WITH METRIC CYLINDRICAL  
THREAD ISO 6149-2**

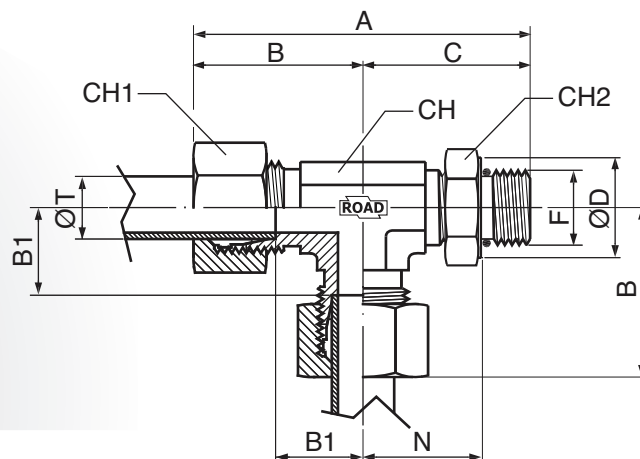

SERIE	T	CODE	F	CH	CH1	CH2	C	N	A	B	B1	D	Pressure
	Ø			mm	mm	mm	mm	mm ±1	mm	mm	mm	Ø	Wp
L	6	D382-06L-10M	M10x1	14	14	14	27,5	22	56,5	29	14	16	315
L	8	D382-08L-12M	M12x1,5	14	17	17	32	22,5	63	31	16	18	315
L	10	D382-10L-14M	M14x1,5	19	19	19	35	26	67	32	17	19	315
L	12	D382-12L-16M	M16x1,5	19	22	22	36	28,5	70	34	19	22,9	315
L	15	D382-15L-18M	M18x1,5	22	27	24	41	31	77	36	21	26,3	315
L	18	D382-18L-22M	M22x1,5	27	32	27	45	36	85	40	24	28,3	250
L	22	D382-22L-27M	M27x2	33	36	32	49,5	38	93,5	44	28	34,5	160
L	28	D382-28L-33M	M33x2	41	41	41	54	41	101	47	31	44,5	160
L	35	D382-35L-42M	M42x2	48	50	50	62	49	121	59	38	53	160
L	42	D382-42L-48M	M48x2	48	60	55	65	52	126	61	38	58	160
S	6	D382-06S-12M	M12x1,5	14	17	17	33	22,5	63,5	30,5	15,5	18	315
S	8	D382-08S-14M	M14x1,5	19	19	19	36	26	69	33	18	19	315
S	10	D382-10S-16M	M16x1,5	19	22	22	38	28,5	72	34	18	22,9	315
S	12	D382-12S-18M	M18x1,5	22	24	24	43	29,5	81	38	22	26,3	315
S	16	D382-16S-22M	M22x1,5	27	30	27	50	36	93	43	25	28,3	250
S	20	D382-20S-27M	M27x2	33	36	32	53,5	38	102,5	49	28	34,5	250
S	25	D382-25S-33M	M33x2	41	46	41	57	41	111,5	54,5	30,5	44,5	160
S	30	D382-30S-42M	M42x2	48	50	50	68	49	130	63	36	53	160
S	38	D382-38S-48M	M48x2	48	60	55	69	52	134	65	34	58	160